

POMPĂ SUBMERSIBILĂ DE DRENAJ DM 210



Rotor din fonta



Putere absorbită P1:

3.3 kW

Putere P2:

1.5 kW

Alimentare:

230 V / 50 Hz

Înălțime de refulare max.:

19.9 m

Debit maxim:

1000 l/min

Diametru maxim pasaj particule solide:

Ø 50 mm

Adancime maximă de imersie:

20 m

Debit Q (m ³ /h – l/min)										
0	6	12	18	24	30	36	42	48	54	60
0	100	200	300	400	500	600	700	800	900	1000
Înălțime de refulare H (m)										
19.9	18.4	16.7	15.2	13.8	12.4	11.3	10.1	8.6	7.0	5.2

Temperatura maximă a apei:	40 °C
Corp pompă:	fontă
Rotor pompă:	fonta
Etanșare mecanică:	dublă, cu bariera de ulei: carbura siliciu + ceramica grafit
Motor cu inductie:	2 poli, în baie de ulei (necesita condensator 50uF)
Arbore motor:	otel inox AISI 304
Clasă de izolație:	F
Clasă de protecție:	IP68
Cablu	H07 RNF - 10 m
Suruburi:	otel inox A2
Suport:	otel galvanizat
Garnituri:	NBR

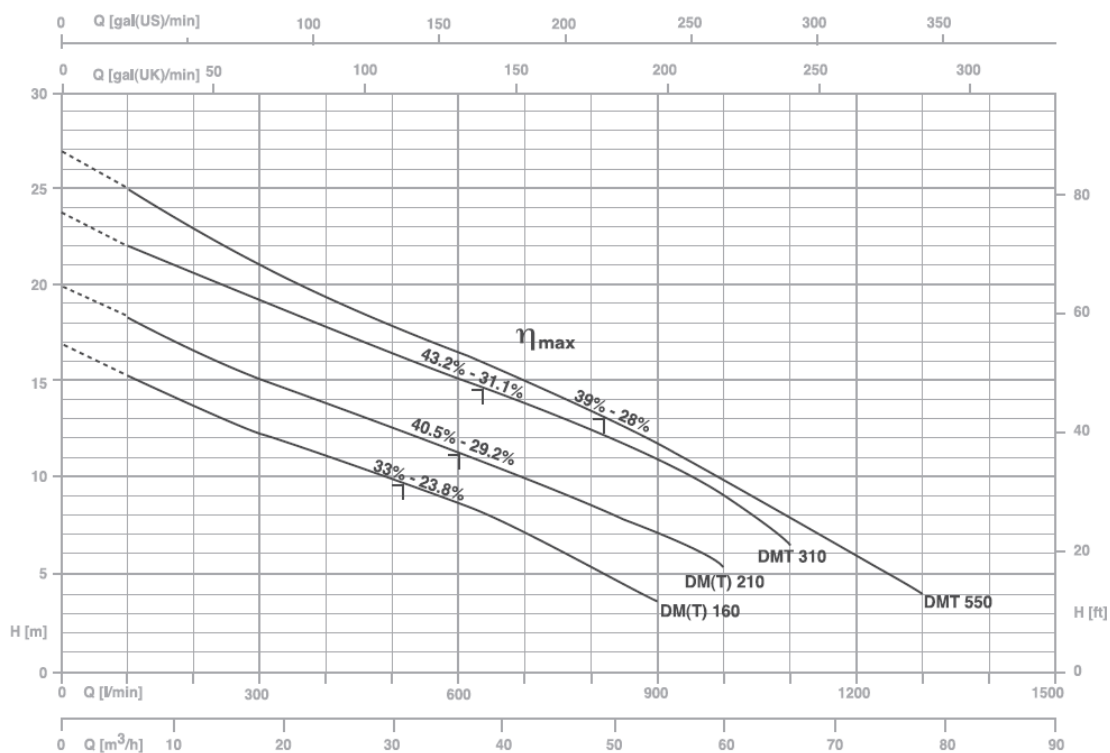

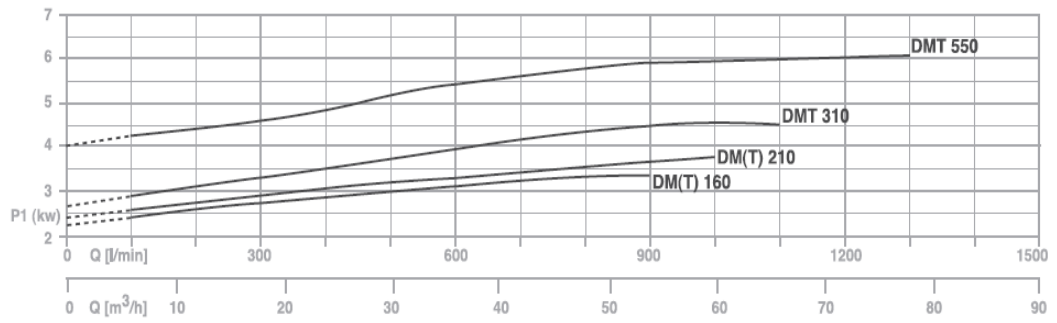

ACCESORII

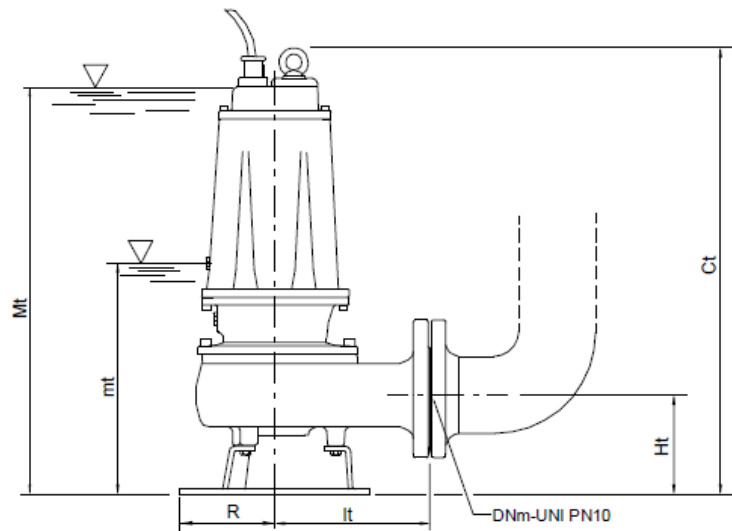
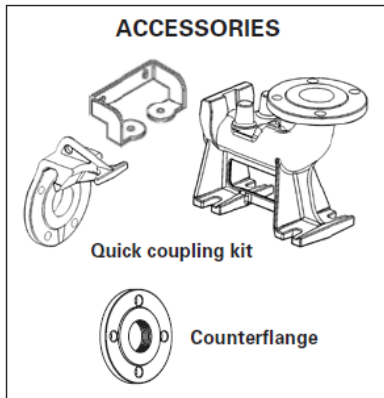

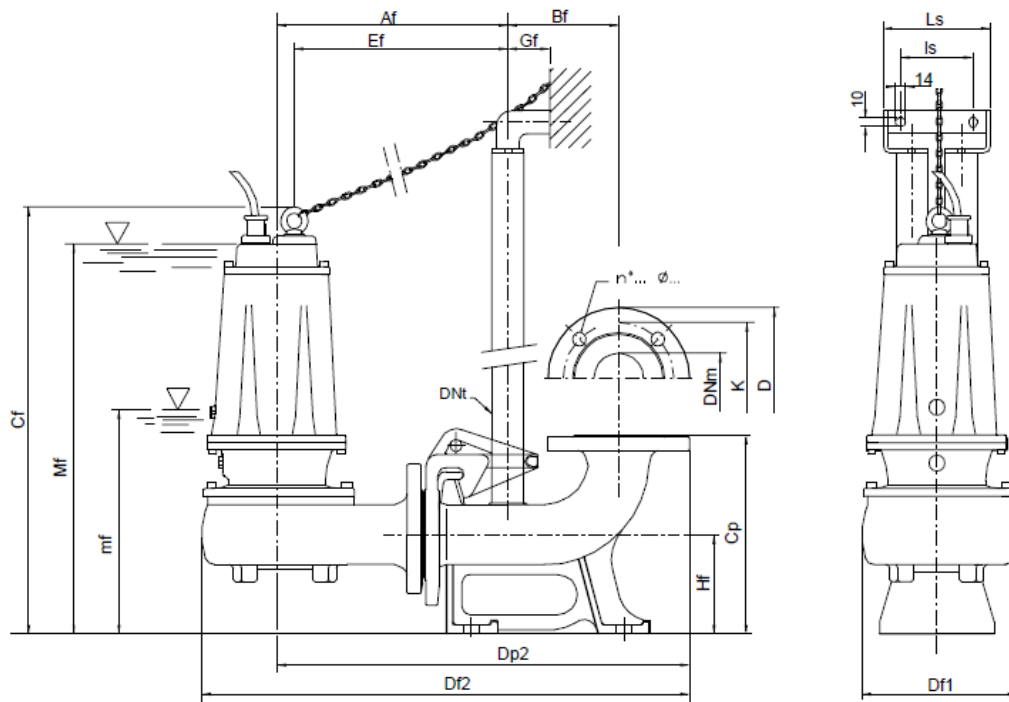

Mt/Mf – nivel minim de functionare in regim continuu

Mt/mf – nivel minim de functionare

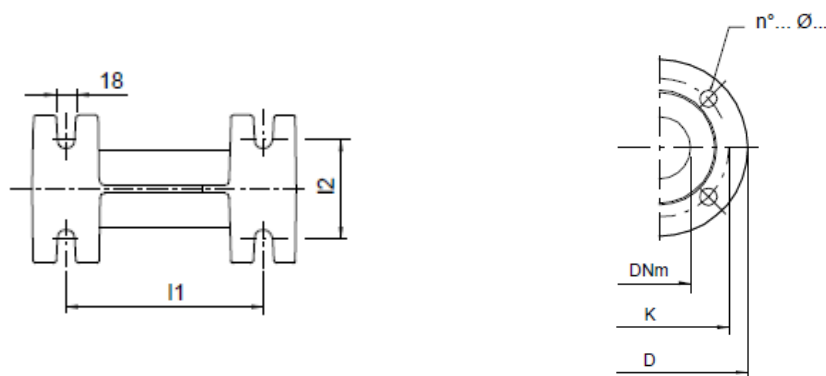

TYPE	DIMENSIONS (mm)							
	Ct	Ht	R	lt	mt	Mt	DNm	
DMT 160	551	123	117	191	243	513	65	39
DM 160-DMT 210	551	123	117	191	243	513	65	40
DM 210-DMT 310	551	123	117	191	243	513	65	41
DMT 550	645	148	160	210	285	600	80	69
DMT 1000	725	178	180	232	358	670	80	93

TYPE	DIMENSIONS (mm)																	
	Af	Bf	Cf	Cp	Df1	Df2	Dp2	DNt	Ef	Gf	Hf	I1	I2	Is	Ls	mf	Mf	DNm
DMT 160/P	303	145	560	260	200	639	542	1" 1/4	280	55	130	200	100	95	140	251	521	65
DM 160-DMT 210/P	303	145	560	260	200	639	542	1" 1/4	280	55	130	200	100	95	140	251	521	65
DM 210-DMT/310	303	145	560	260	200	639	542	1" 1/4	280	55	130	200	100	95	140	251	521	65
DMT 550/P	350	165	690	340	220	722	615	2"	319	85	190	250	140	130	180	327	642	80
DMT 1000/P	370	165	745	340	240	750	638	2"	350	85	190	250	140	130	180	380	690	80